

Engine D1803-M

Engine power 28,3 kW - 38,0 HP

Operating weight 3.800 - 3.950 kg

# ES 40 ZT

**Concrete solutions. Always**



 **EUROCOMACH®**

# TECHNICALS SPECIFICATIONS

Weight with canopy	kg	3.800
Weight with cabin	kg	3.950
Travelling speed Lo-Hi	km/h	2,5 - 4,6
Slew speed	rpm	9

## ENGINE

Type		KUBOTA D1803-M
Max Power	kW-HP	28,3 - 38
Displacement	cc	1.826
Number of cylinders	n°	3
Cooling		water
Consumption	lt/h	4,5
Alternator	V (A)	12 (40)
Battery	V (Ah)	12 (80)

## HYDRAULIC SYSTEM

Type		open center
Pump type		2 variable piston pumps + 1 gear pilot pump
Pump displacement	cc	2 x 15+14
Pump capacity	lt/min	2 x 37,5 + 35
Auxiliary system	lt/min	68
Circuit calibration pressure	bar	230

## PERFORMANCES

Bucket breaking force (standard arm) ISO 6015	daN	3.200
Arm breaking force (standard arm) ISO 6015	daN	1.950
Traction force	daN	3.400
Ground pressure with canopy (with cabin)	kg/cm <sup>2</sup>	0,32 (0,33)
Max slope		60% - 30°

## DIMENSIONS

Total width	mm	1.700
Max dumping height with cabin and standard arm (optional arm)	mm	3.530 (3.680)
Total height	mm	2.535
Rear rotation radius	mm	845
Max digging depth standard arm (optional arm)	mm	3.200 (3.450)
Digging arm length std (optional)	mm	1.400 (1.650)
Tracks width	mm	350
Rollers (for each side)	n°	4 lower + 1 upper

## FILLINGS

Fuel tank	lt	30
Hydraulic oil tank	lt	30
Hydraulic circuit capacity	lt	54
Cooling system capacity	lt	8
Engine oil	lt	7

## CONTROLS

Bucket, boom, swing, slew		2 joisticks
Travel and steering		2 pilot levers
Dozer blade		1 pilot lever
Auxiliary hydraulics system		electroproportional switch on right joystick
Boom swing		electroproportional switch on left joystick

# ES 40 ZT

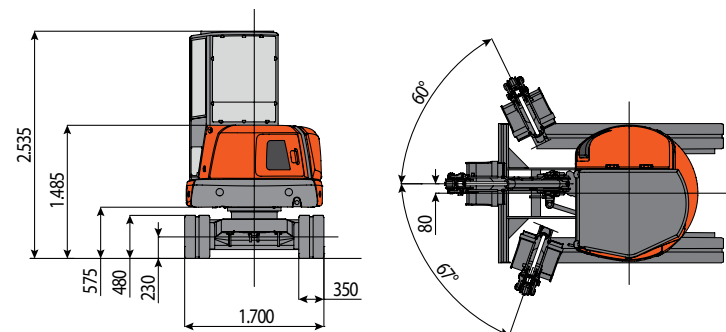
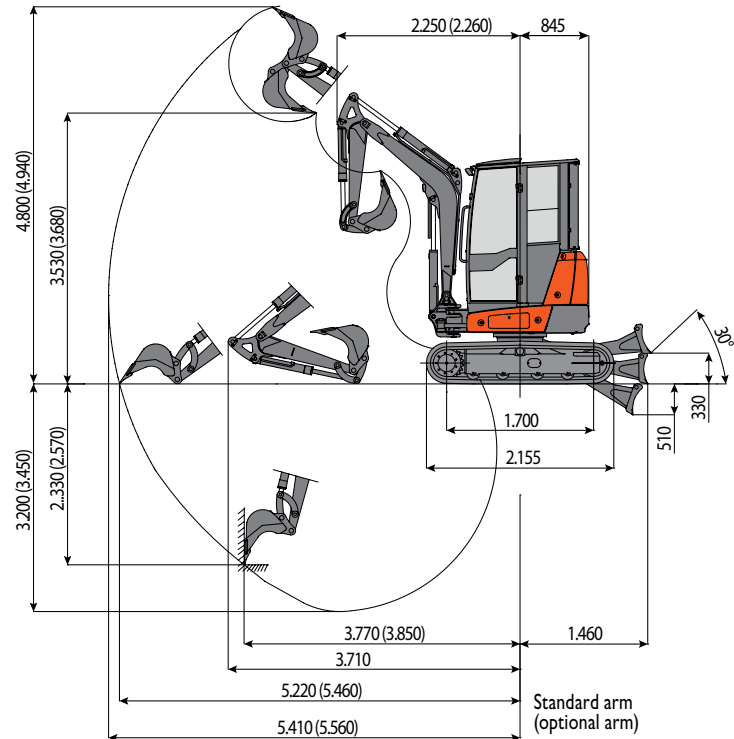

## LIFTING CAPACITY

Opening arm from the rotation's center (m)  
Lifting capacity (kg) at 1.0 m height

	2,5	3	3,5	4	4,5	MAX
Dozer blade lifted	1231	984	803	716	674	648
Idler center	1096	863	665	536	450	437
Crawler center	999	770	613	500	413	390

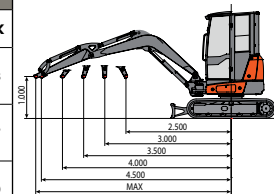

The lifting capacity is based on the ISO 10567 and it does not exceed more than the 75% of static tipping load or more than the 87% of the hydraulic lifting capacity of the machine.



**EUROCOMACH®**

MADE IN ITALY

**Sampierana S.p.a.**

47021 S. Piero in Bagno (FC)

via Leonardo da Vinci, 40

Tel +39 0543.904211

Fax +39 0543.918520

www.eurocomach.com