

**Engine 2TNV70**  
**Engine power 7,6 kW - 10 HP**  
**Operating Weight 1.060 kg**

# **ES 10 ZT**

**Concrete solutions. Always**



# TECHNICALS SPECIFICATIONS

Weight with canopy (rubber tracks)	kg	1.060
Weight with cabin (rubber tracks)	kg	1.060
Travelling speed	km/h	1,8 - 3,8
Slew speed	rpm	9,5

## ENGINE

Type		YANMAR 2TNV70
Power (2260rpm)	kW- HP	7,6 - 10
Displacement	cc	570
Number of cylinders	n°	2
Cooling		water
Consumption	lt/h	2,5
Alternator	V (A)	12 (40)
Battery	V (Ah)	12 (45)

## HYDRAULIC SYSTEM

Pump type		n°2 gear pumps
Pump displacement	cc	4,8 - 4,8
Pump capacity	lt/min	23
Auxiliary system	lt/min	23
Circuit calibration pressure	bar	170

## PERFORMANCES

Bucket breaking force (standard arm) ISO 6015	daN	1.010
Arm breaking force (standard arm) ISO 6015	daN	752
Traction force	daN	1.050
Ground bearing pressure	kg/cm <sup>2</sup>	0,28
Max slope		60% - 30°

## DIMENSIONS

Total width	mm	760 - 990
Max dumping height with cabin and standard arm (optional arm)	mm	2.070 (2.180)
Total height	mm	2.200
Rear rotation radius	mm	500
Max digging depth standard arm (optional arm)	mm	1.620 (1.770)
Digging arm length std (optional)	mm	750 (900)
Tracks width	mm	180
Rollers (for each side)	n°	2

## FILLINGS

Fuel tank	lt	10
Hydraulic oil tank	lt	9,5
Hydraulic circuit capacity	lt	15
Cooling system capacity	lt	5
Engine oil	lt	1,5

## CONTROLS

Bucket, boom, swing, slew		2 levers
Travel and steering		2 levers
Dozer blade		lever
Auxiliary hydraulics system		left pedal
Boom swing		right pedal

# ES 10 ZT

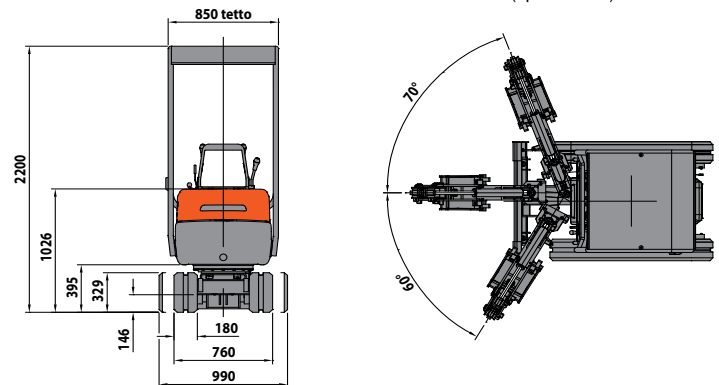
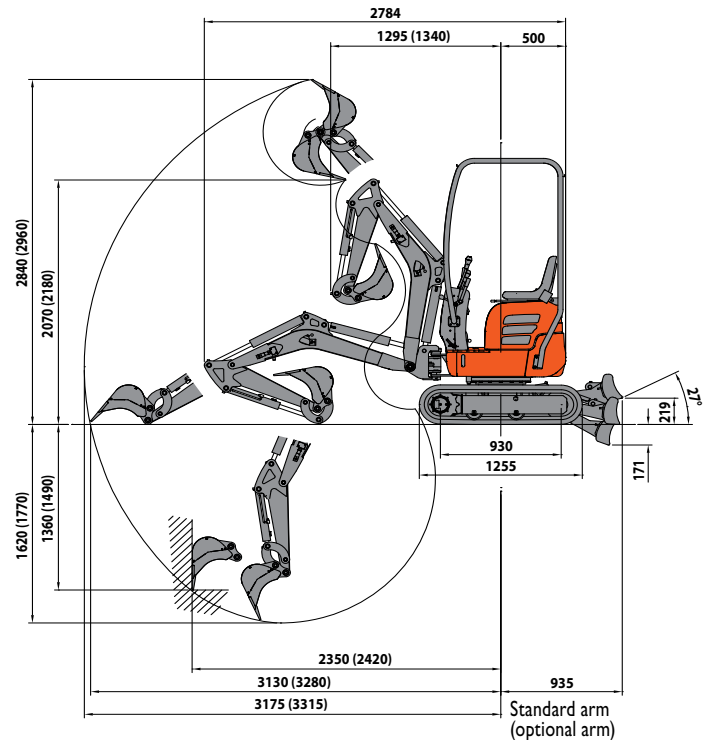

LIFTING CAPACITY				
Opening arm from the rotation's center (m)				
Lifting capacity (kg) at 1.0 m height				
	1,5	2	2,5	MAX
Dozer front end	290	175	125	105
Idler center	335	235	200	175
Crawler Center	335	190	115	90

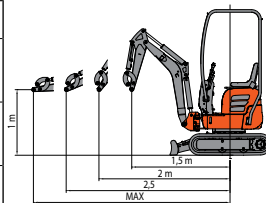

The lifting capacity is based on the ISO 10567 and it does not exceed more than the 75% of static tipping load or more than the 87% of the hydraulic lifting capacity of the machine.



**EUROCOMACH**<sup>®</sup>

MADE IN ITALY

**Sampierana S.p.a.**

47021 S. Piero in Bagno (FC)

via Leonardo da Vinci, 40

Tel +39 0543.904211

Fax +39 0543.918520

www.eurocomach.com