

Engine 3TNV70

Engine power 11,2 kW - 15,3 HP

Operating Weight 1.730 - 1.810 kg

ES 18 ZT

Concrete solutions. Always



TECHNICALS SPECIFICATIONS

Weight with canopy (rubber tracks)	kg	1.730
Weight with cabin (rubber tracks)	kg	1.810
Travelling speed	km/h	2,2 - 4,2
Slew speed	rpm	12

ENGINE

Type		YANMAR 3TNV70
Power (2260rpm)	kW- HP	11,2 - 15,2
Displacement	cc	854
Number of cylinders	n°	3
Cooling		water
Consumption	lt/h	2,5
Alternator	V (A)	12 (35)
Battery	V (Ah)	12 (65)

HYDRAULIC SYSTEM

Pump type		variable flow
Pump displacement	cc	8+8+6,5
Pump capacity	lt/min	17,6+17,6+14,3
Auxiliary system	lt/min	36
Circuit calibration pressure	bar	210

PERFORMANCES

Bucket breaking force (standard arm) ISO 6015	daN	1.550
Arm breaking force (standard arm) ISO 6015	daN	1.050
Traction force	daN	1.500
Ground bearing pressure	kg/cm ²	0,28
Max slope		60% - 30°

DIMENSIONS

Total width	mm	990 - 1.300
Max dumping height with cabin and standard arm (optional arm)	mm	2.690 (2.780)
Total height	mm	2.357
Rear rotation radius	mm	650
Max digging depth standard arm (optional arm)	mm	2.300 (2.450)
Digging arm length std (optional)	mm	1.150 (1.350)
Tracks width	mm	230
Rollers number (for each side)	n°	3

FILLINGS

Fuel tank	lt	20
Hydraulic oil tank	lt	20
Hydraulic circuit capacity	lt	30
Cooling system capacity	lt	4
Engine oil	lt	2,8

CONTROLS

Bucket, boom, swing, slew		2 joisticks
Travel and steering		levers/pedals
Dozer blade		lever
Auxiliary hydraulics system		left pedal
Boom swing		right pedal

ES 18 ZT

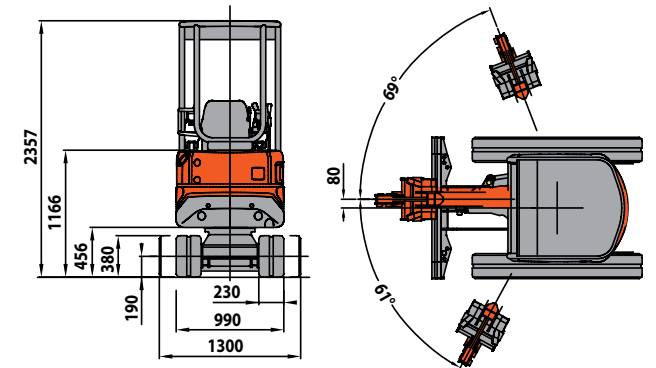
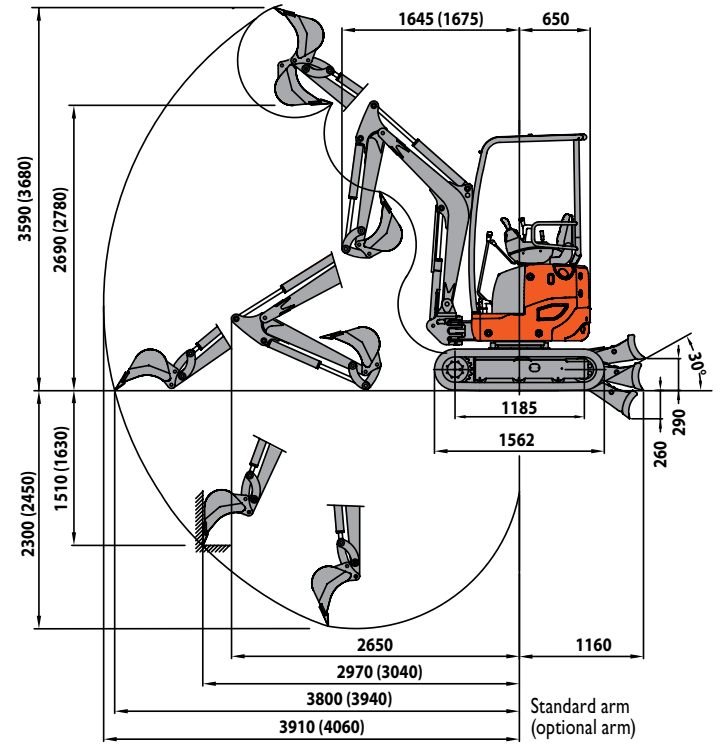

LIFTING CAPACITY

Opening arm from the rotation's center (m)
Lifting capacity (kg) at 1.0 m height

	1,5	2	2,5	3	MAX
Idler center	660	440	360	310	250
Dozer front end	610	410	280	205	180
Lateral extended chassis	610	410	235	195	160

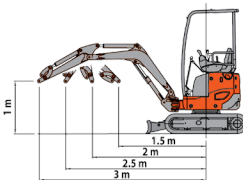

The lifting capacity is based on the ISO 10567 and it does not exceed more than the 75% of static tipping load or more than the 87% of the hydraulic lifting capacity of the machine.



EUROCOMACH®

MADE IN ITALY

Sampierana S.p.a.

47021 S. Piero in Bagno (FC)

via Leonardo da Vinci, 40

Tel +39 0543.904211

Fax +39 0543.918520

www.eurocomach.com