

Engine 3TNV76

Engine power 13,8 kW - 18,5 HP

Operating Weight 2.290 - 2.450 kg

ES 22 SR

Concrete solutions. Always



 **EUROCOMACH®**

TECHNICALS SPECIFICATIONS

Weight with canopy (rubber tracks)	kg	2.150
Weight with cabin (rubber tracks)	kg	2.310
Travelling speed	km/h	2,0 - 4,0
Slew speed	rpm	10
ENGINE		
Type		YANMAR 3TNV76
Power (2260rpm)	kW-HP	13,8 - 18,5
Displacement	cc	1.116
Number of cylinders	n°	3
Cooling		water
Alternator	V (A)	12 (35)
Battery	V (Ah)	12 (65)
HYDRAULIC SYSTEM		
Pump type		variable flow
Pump displacement	cc	11+11+8
Pump capacity	lt/min	24+24+17,5
Auxiliary system	lt/min	20
Circuit calibration pressure	bar	205
PERFORMANCES		
Bucket breaking force (standard arm) ISO 6015	daN	1.910
Arm breaking force (standard arm) ISO 6015	daN	1.520
Traction force	daN	2.000
Ground bearing pressure with canopy (with cabin)	kg/cm ²	0,38 (0,40)
Max slope		60% - 30°
DIMENSIONS		
Total width	mm	1.300
Max dumping height with cabin and standard arm (optional arm)	mm	2.953 (3.075)
Total height	mm	2.385
Rear rotation radius	mm	750
Max digging depth standard arm (optional arm)	mm	2.540 (2.790)
Digging arm length std (optional)	mm	1.150 (1.400)
Tracks width	mm	250
Rollers number (for each side)	n°	4
FILLINGS		
Fuel tank	lt	20
Hydraulic oil tank	lt	29
Hydraulic circuit capacity	lt	40
Cooling system capacity	lt	5
Engine oil	lt	2,8
CONTROLS		
Bucket, boom, swing, slew		2 joisticks
Travel and steering		levers/pedals
Dozer blade		lever
Auxiliary hydraulics system		left pedal
Boom swing		right pedal

ES 22 SR

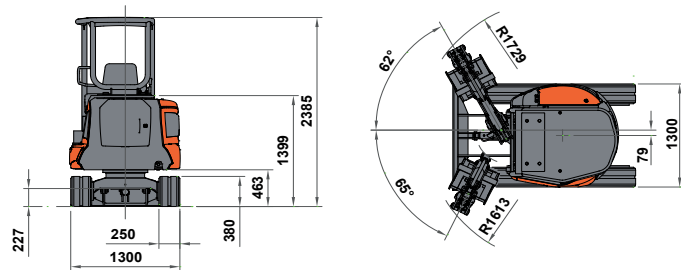
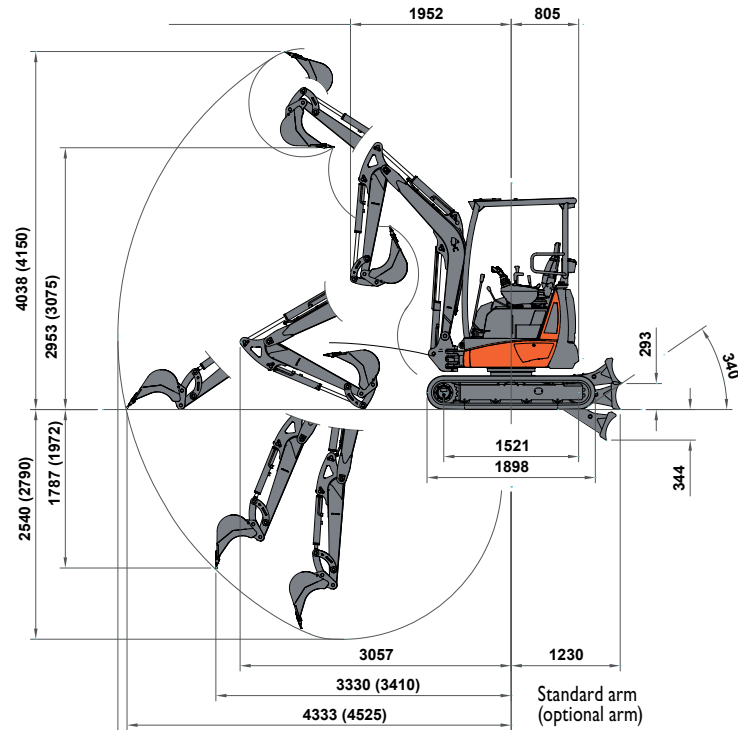

LIFTING CAPACITY				
Opening arm from the rotation's center (m)				
Lifting capacity (kg) at 1.0 m height				
	2	2,5	3	MAX
Idler center	850	580	410	300
Dozer front end	890	630	500	420
Lateral extended chassis	565	370	290	215

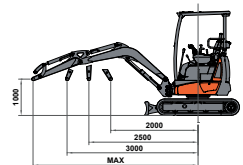

The lifting capacity is based on the ISO 10567 and it does not exceed more than the 75% of static tipping load or more than the 87% of the hydraulic lifting capacity of the machine.



EUROCOMACH®

MADE IN ITALY

Sampierana S.p.a.

47021 S. Piero in Bagno (FC)

via Leonardo da Vinci, 40

Tel +39 0543.904211

Fax +39 0543.918520

www.eurocomach.com