

Engine V2607-DI

Engine power 33,8 kW - 46 HP

Operating weight 5.500 - 5.600 kg

ES 57 ZT

Concrete solutions. Always



TECHNICALS SPECIFICATIONS

Weight with canopy	kg	5.500
Weight with cabin	kg	5.600
Travelling speed Lo-Hi	km/h	2,6 - 5,2
Slew speed	rpm	11

ENGINE

Type		KUBOTA V2607-DI
Max Power	kW-HP	33,8 - 46
Displacement	cc	2.615
Number of cylinders	n°	4
Cooling		water
Consumption	V (A)	12 (60)
Battery	V (Ah)	12 (100)

HYDRAULIC SYSTEM

Type	load sensing closed center system with flow sharing control valve	
Pump type	1 ls variable pump + 1 gear pump	
Pump displacement	cc	65 + 8
Pump capacity	lt/min	140 + 17
Circuit calibration pressure	bar	260
Auxiliary system:		
Max capacity	lt/min	70
Max pressure	bar	200

PERFORMANCES

Bucket breaking force (standard arm) ISO 6015	daN	4.500
Arm breaking force (standard arm) ISO 6015	daN	2.800
Traction force	daN	5.200
Ground pressure with canopy (with cabin)	kg/cm ²	0,33 (0,34)
Max slope		60% - 30°

DIMENSIONS

Total width	mm	1.980
Max dumping height with cabin and standard arm (optional arm)	mm	4.090 (4.240)
Total height	mm	2.560
Rear rotation radius	mm	1.000
Max digging depth standard arm (optional arm)	mm	3.850 (4.100)
Digging arm length std (optional)	mm	1.650 (1.900)
Tracks width	mm	400
Rollers (for each side)	n°	5 lower + 1 upper

FILLINGS

Fuel tank	lt	75
Hydraulic oil tank	lt	65
Hydraulic circuit capacity	lt	85
Cooling system capacity	lt	12
Engine oil	lt	9

CONTROLS

Bucket, boom, swing, slew		2 pilot joisticks
Track movement (including counter rotation)		2 pilot levers
Dozer blade		1 pilot lever
Auxiliary hydraulics system (single or double effect)		electroproportional switch on right joystick
Boom swing		electroproportional switch on left joystick

ES 57 ZT

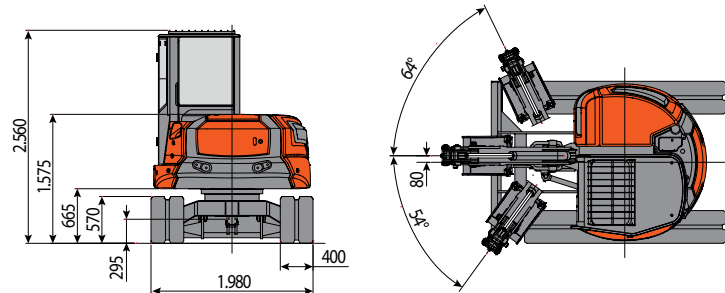
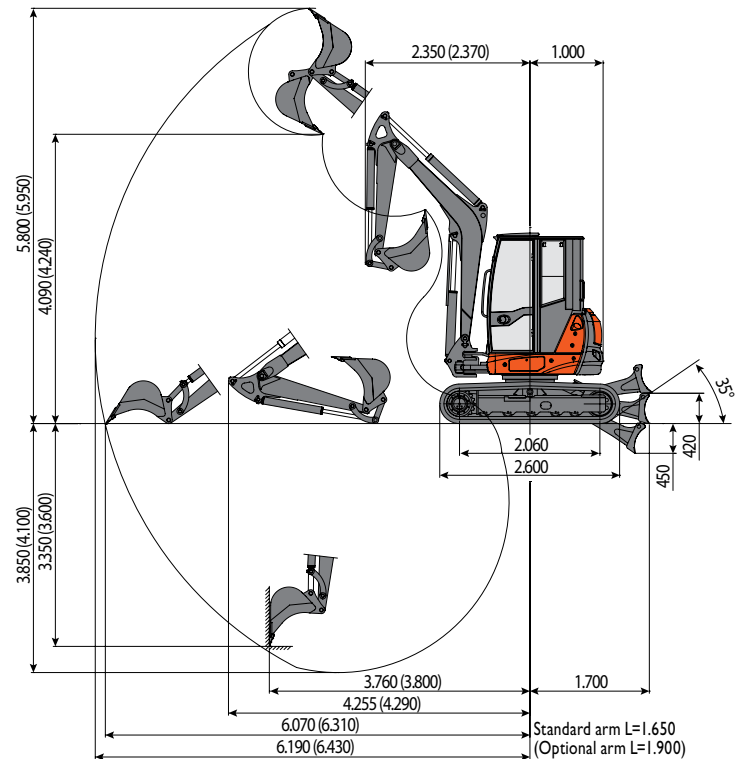

LIFTING CAPACITY						
Opening arm from the rotation's center (m)						
Lifting capacity (kg) at 1.0 m height						
	3	3,5	4	4,5	5	MAX
Idler center	2514	2001	1662	1443	1327	1248
Dozer blade lifted	1793	1403	1125	949	814	705
Crawler center	1388	1082	900	743	640	555

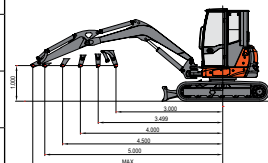

The lifting capacity is based on the ISO 10567 and it does not exceed more than the 75% of static tipping load or more than the 87% of the hydraulic lifting capacity of the machine.



EUROCOMACH®

MADE IN ITALY

Sampierana S.p.a.

47021 S. Piero in Bagno (FC)

via Leonardo da Vinci, 40

Tel +39 0543.904211

Fax +39 0543.918520

www.eurocomach.com